



Manufactured by:  
Backyard Discovery  
3305 Airport Drive, Pittsburg, KS  
66762 800-856-4445

Basepoint Business Centre: Rivermead Drive, Westlea, Swindon SN5 7EX Phone: 0800-118-2476 J.P. Coenstraat 7, The Bridge, The Hague, 2595 WP, Netherlands Phone: 08005678990

# TEAK PLANTER A

## MODEL # : 2204058

**THE ASSEMBLY MANUAL MUST BE RETAINED SINCE  
IT CONTAINS IMPORTANT INFORMATION**



Please visit [www.backyarddiscovery.com](http://www.backyarddiscovery.com)  
For the most up to date assembly manual, to register your product, or to order  
replacement parts *Para obtener instrucciones en español, visite*  
[www.backyarddiscovery.com](http://www.backyarddiscovery.com)



**INSTALLATION  
SERVICES  
AVAILABLE!**  
*See inside for details*

# OWNER'S MANUAL - BASIC SETUP DIMENSIONS & ASSEMBLY NOTES

It is critically important that you start with square and level footings, concrete pad or deck to attach your structure

- Pay close attention to the items needed for each step. Make sure you are using the correct hardware for each step. Using incorrect hardware may result in improper assembly

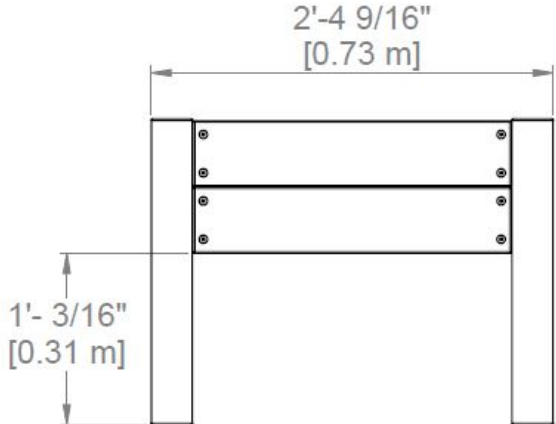
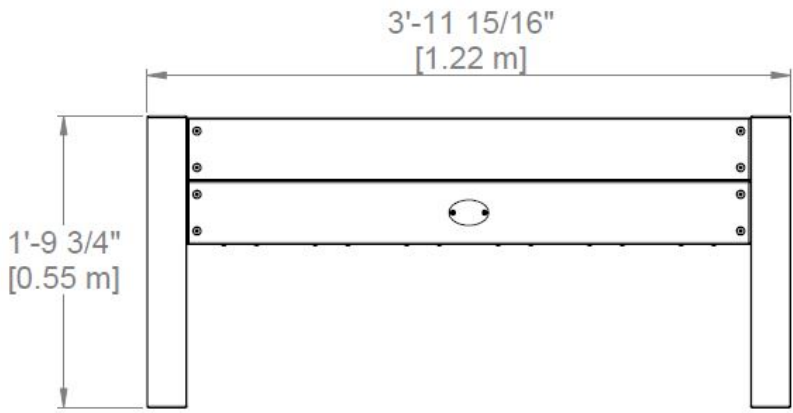
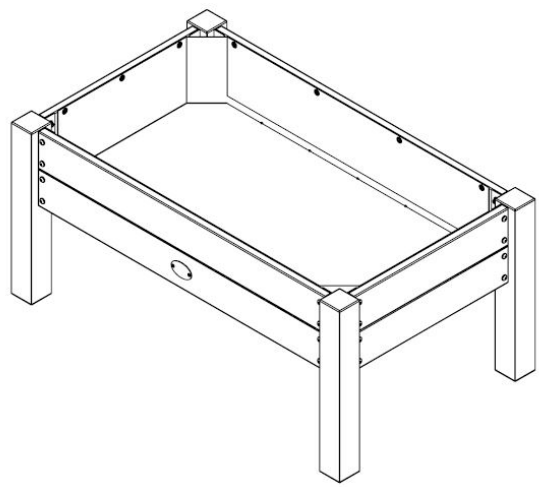
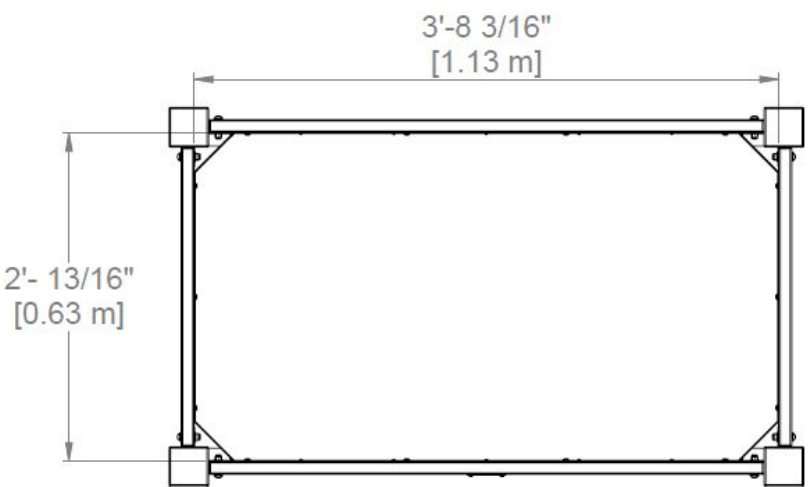

# OWNER'S MANUAL - PARTS IDENTIFICATION

## Wood Components (Not to Scale)



**G01 | LONG SIDE BOARD-W4L16326**  
(x4) | 7/8"x4 3/4"x41 15/16" (22x120x1066)



**G02 | SHORT SIDE BOARD-W4L16327**  
(x4) | 7/8"x4 3/4"x22 5/8" (22x120x574)



**G03 | SLAT-W4L16328**  
(x6) | 7/8"x4 3/4"x24 1/2" (22x120x623)

## Accessory Components (Not to Scale)

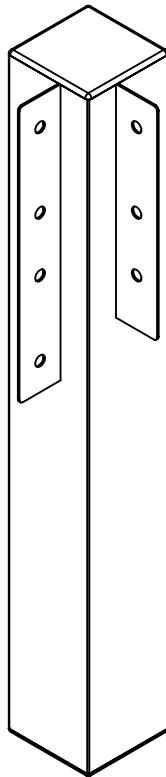

**A4M01502**  
(x2) | POST ASSEMBLY

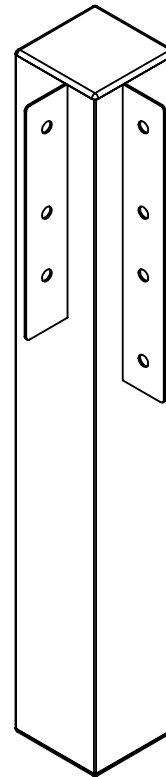

**A4M01503**  
(x2) | POST ASSEMBLY

# OWNER'S MANUAL - PARTS IDENTIFICATION

## Accessory Components (Not to Scale)

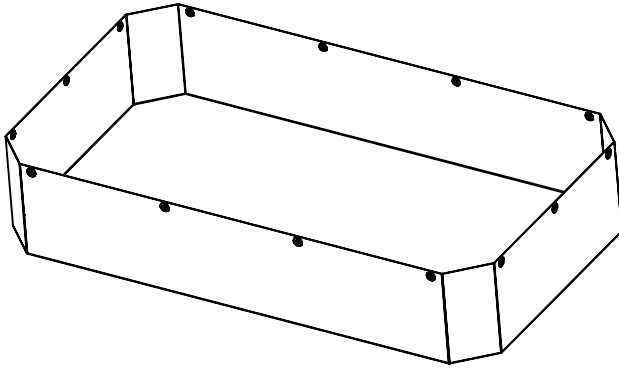

**A6P00510** | PLANTER LINER  
(x1)

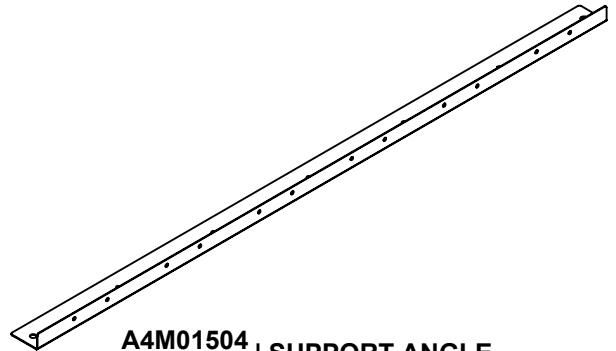

**A4M01504** | SUPPORT ANGLE  
(x2)

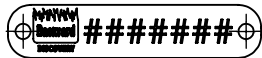

**A4M01229** | PRODUCT NUMBER TAG  
(x1)



**A100241** | BYD ID TAG  
(x1)

## Hardware Components (Not to Scale)



**H100202** | SCREW PWH BLK  
(x54) | 8 x 5/8



**H100127** | SCREW PPH BLK  
(x2) | 4 x 5/8

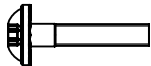

**H100397** | BOLT WH BLK  
(x34) | 1/4 x 1 1/4



**H100653** | NUT LOCK BLK  
(x34) | 1/4



**H100630** | WASHER FLAT BLK  
(x35) | 8x19

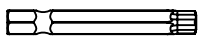

**H100147** | TORX BIT  
(x1) | T-30



**H101100** | MAGNETIC DRIVER  
(x1)



**H100114** | TORX WRENCH  
(x1) | T-30

# PRE-ASSEMBLY STEP 1 - TOOLS REQUIRED



Cordless Drill  
or Electric Drill



Drill  
Attachments:  
Phillips Head



Phillips Screw Driver

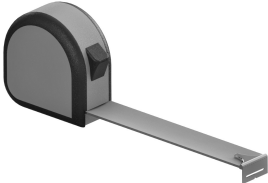

Tape Measure

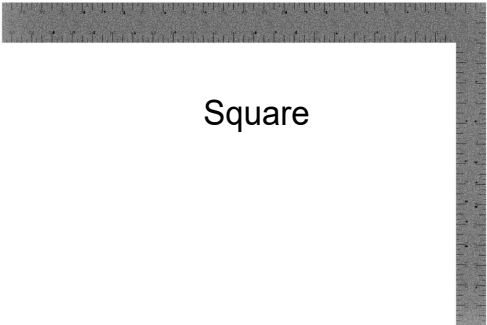

Square



Open End Wrench - 7/16"



Claw Hammer

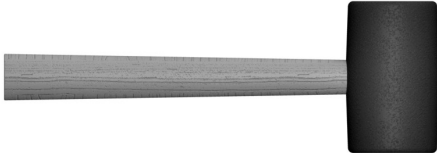

Rubber Mallet  
- Optional



Level 24"

# PRE-ASSEMBLY STEP 2 - SORTING PARTS

It is critical for ease of assembly that you take the time to sort and organize the wood and hardware.

---

## WOOD PARTS:

- Organize wood parts by the three-digit, alpha-numeric number stamped on each board (ex. P01).
- If there are multiple boards with the same stamped number, stack those pieces together.
- Stamps can be found on the flat surface of the boards or on the end of the boards.
- Allow yourself plenty of room - the wood pieces can take up a significant amount of space.

**NOTE: CARTONS ARE NOT ORGANIZED BY BOARD NUMBER.**



## HARDWARE PARTS:

- We recommend that you have a separate table to organize the hardware.
- Hardware bags are printed with a seven-digit, alpha-numeric part number.
- You can organize your hardware by part number or group by hardware type (i.e. bolts, nuts, etc.).
- During assembly you only need to reference the last four digits of the number.

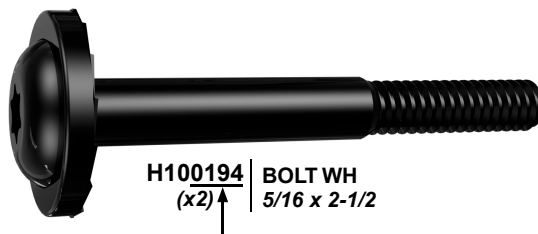

H100194 | BOLT WH  
(x2) ↑ 5/16 x 2-1/2

# STEP 1 - PLANTER ASSEMBLY

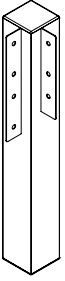

A4M01502 (x2) | POST ASSEMBLY

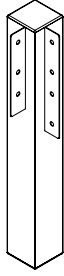

A4M01503 (x2) | POST ASSEMBLY



G02 | SHORT SIDE BOARD-W4L16327  
(x4) | 7/8"x4 3/4"x22 5/8" (22x120x574)

QTY	PART NUMBER	DESCRIPTION
16	H100397	BOLT WH 1/4x1 1/4 BLK
16	H100630	WASHER FLAT 8x19 BLK
16	H100653	NUT LOCK 1/4 BLK

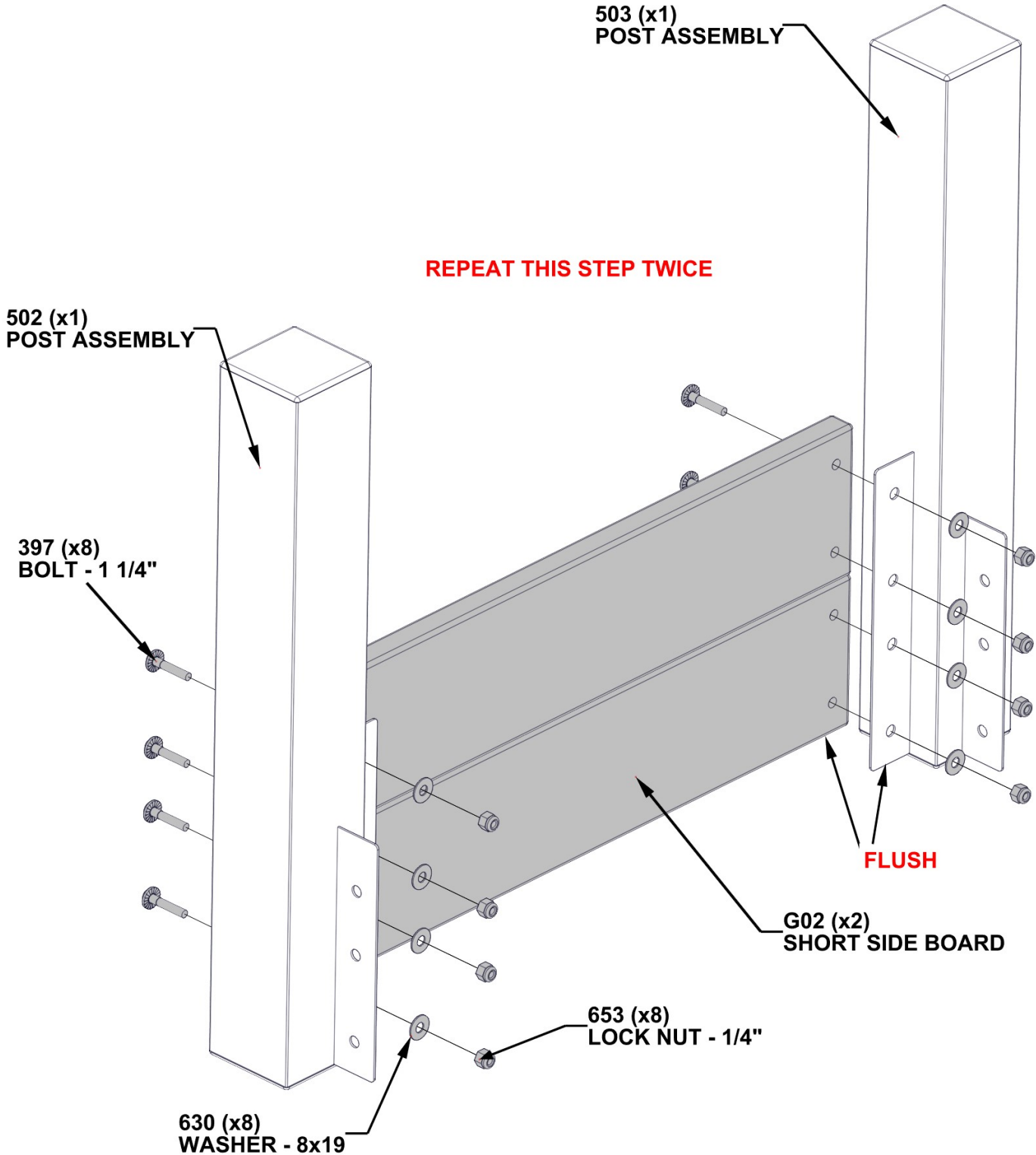

# STEP 2 - PLANTER ASSEMBLY



**G01 | LONG SIDE BOARD-W4L16326**  
 (x1) | 7/8"x4 3/4"x41 15/16" (22x120x1066)

QTY	PART NUMBER	DESCRIPTION
4	H100397	BOLT WH 1/4x1 1/4 BLK
4	H100630	WASHER FLAT 8x19 BLK
4	H100653	NUT LOCK 1/4 BLK

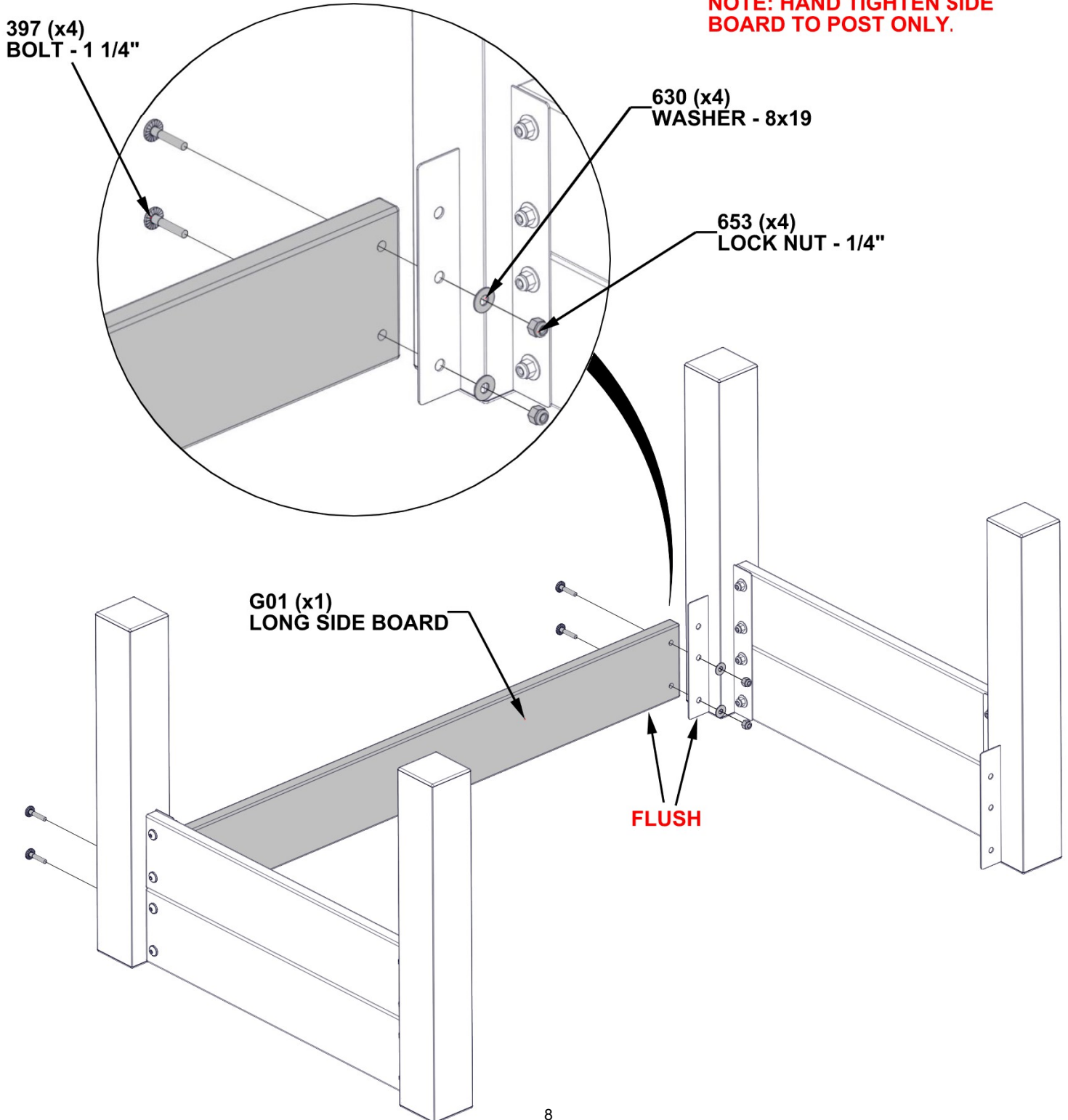



# STEP 3 - PLANTER ASSEMBLY



**G01 | LONG SIDE BOARD-W4L16326**  
 (x1) | 7/8"x4 3/4"x41 15/16" (22x120x1066)

QTY	PART NUMBER	DESCRIPTION
4	H100397	BOLT WH 1/4x1 1/4 BLK
4	H100630	WASHER FLAT 8x19 BLK
4	H100653	NUT LOCK 1/4 BLK

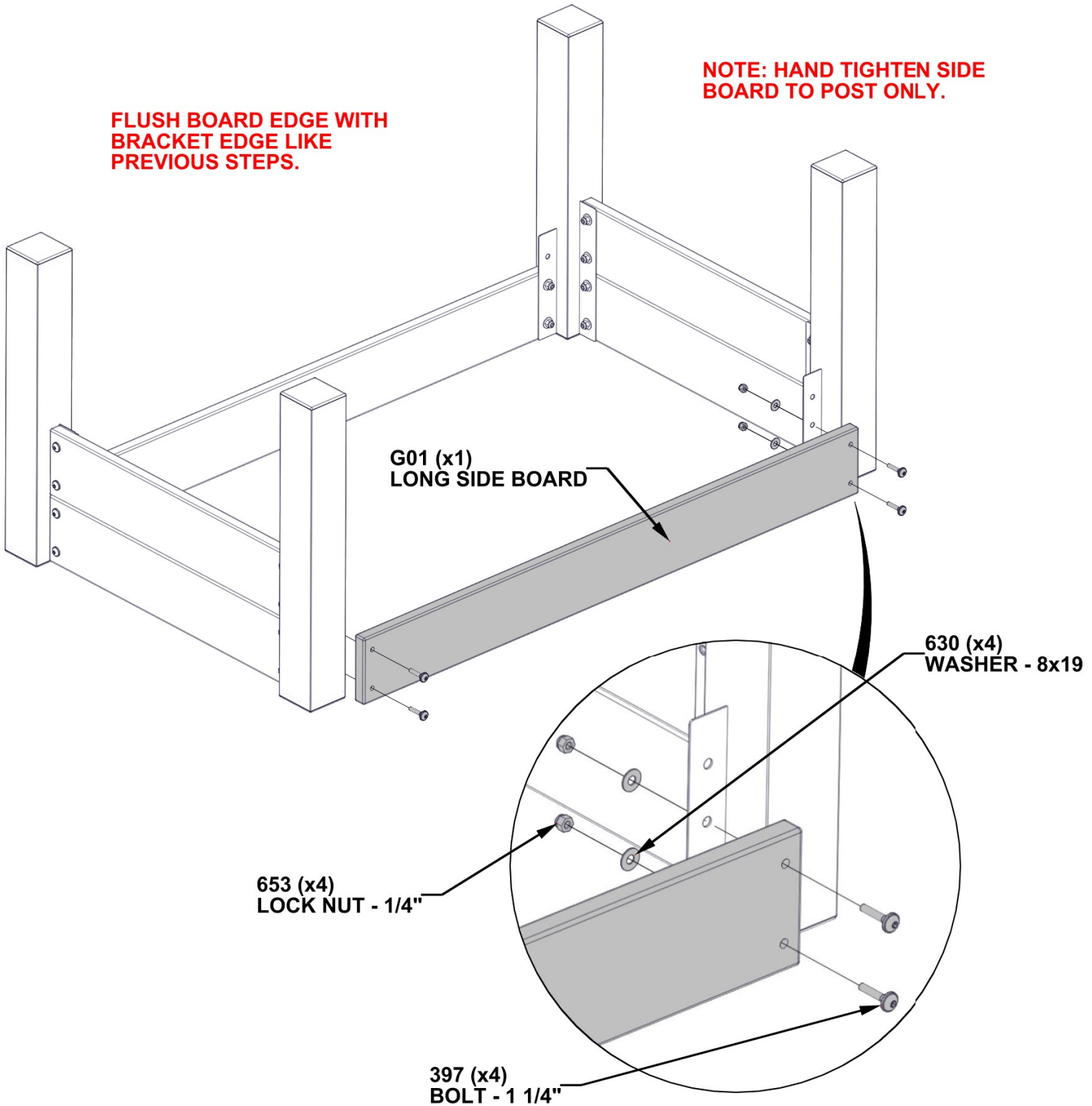

# STEP 4 - PLANTER ASSEMBLY

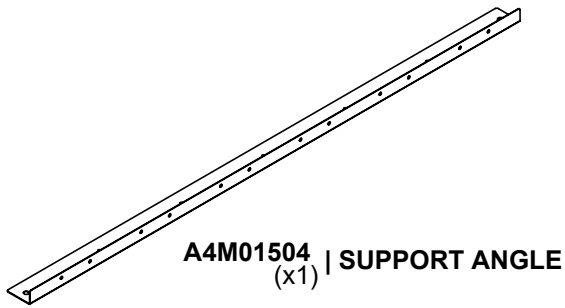

**G01 | LONG SIDE BOARD-W4L16326**  
(x1) | 7/8"x4 3/4"x41 15/16" (22x120x1066)

QTY	PART NUMBER	DESCRIPTION
4	H100397	BOLT WH 1/4x1 1/4 BLK
4	H100630	WASHER FLAT 8x19 BLK
4	H100653	NUT LOCK 1/4 BLK

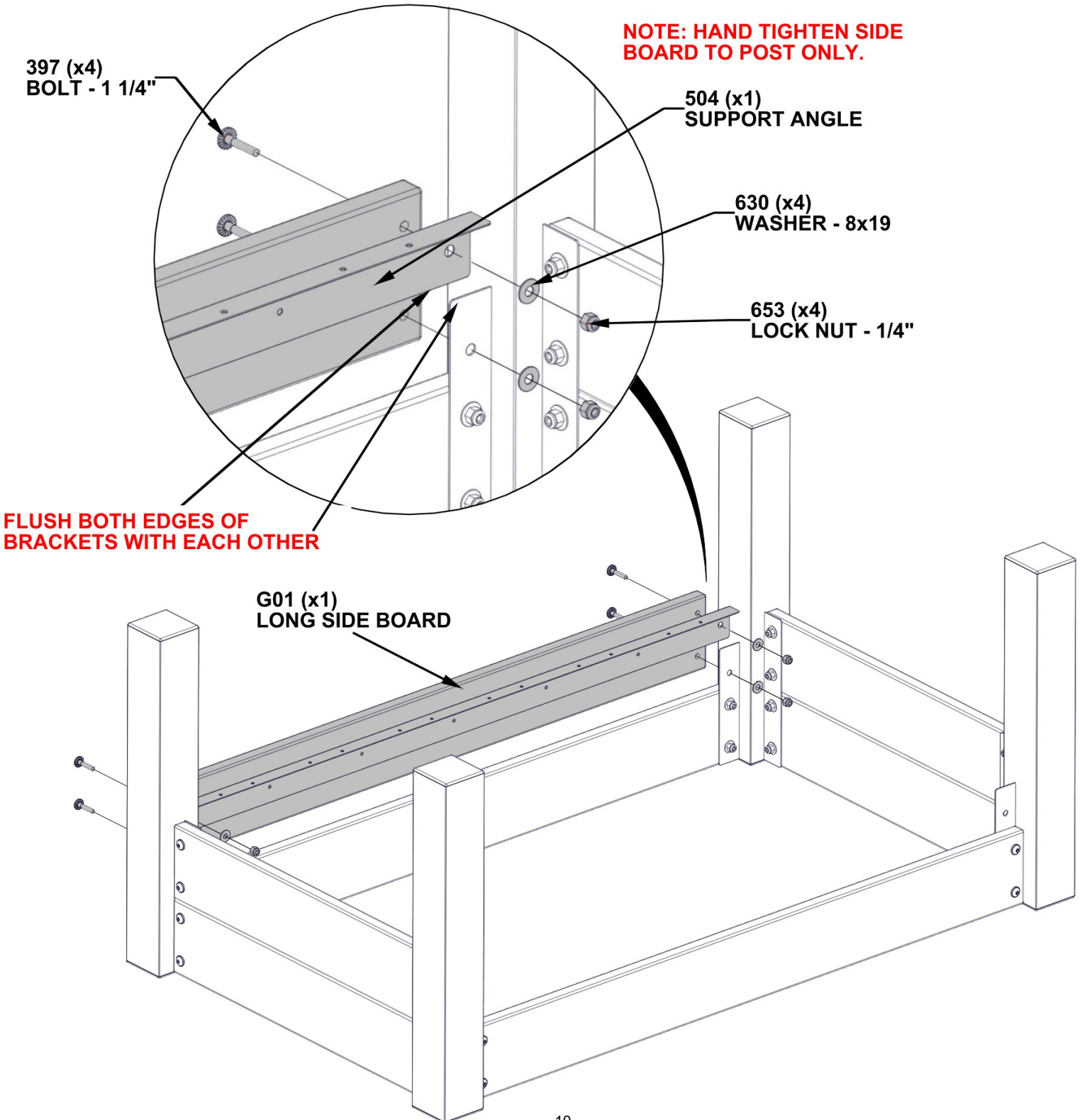

# STEP 5 - PLANTER ASSEMBLY

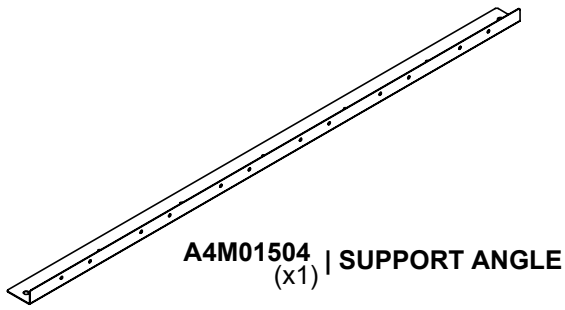

G01 | LONG SIDE BOARD-W4L16326  
(x1) | 7/8"x4 3/4"x41 15/16" (22x120x1066)

QTY	PART NUMBER	DESCRIPTION
4	H100397	BOLT WH 1/4x1 1/4 BLK
4	H100630	WASHER FLAT 8x19 BLK
4	H100653	NUT LOCK 1/4 BLK

**NOTE: TIGHTEN ALL HARDWARE FROM PREVIOUS STEPS.**

397 (x4)  
BOLT - 1 1/4"

504 (x1)  
SUPPORT ANGLE

630 (x4)  
WASHER - 8x19

653 (x4)  
LOCK NUT - 1/4"

**FLUSH BOTH EDGES OF BRACKETS WITH EACH OTHER**

G01 (x1)  
LONG SIDE BOARD

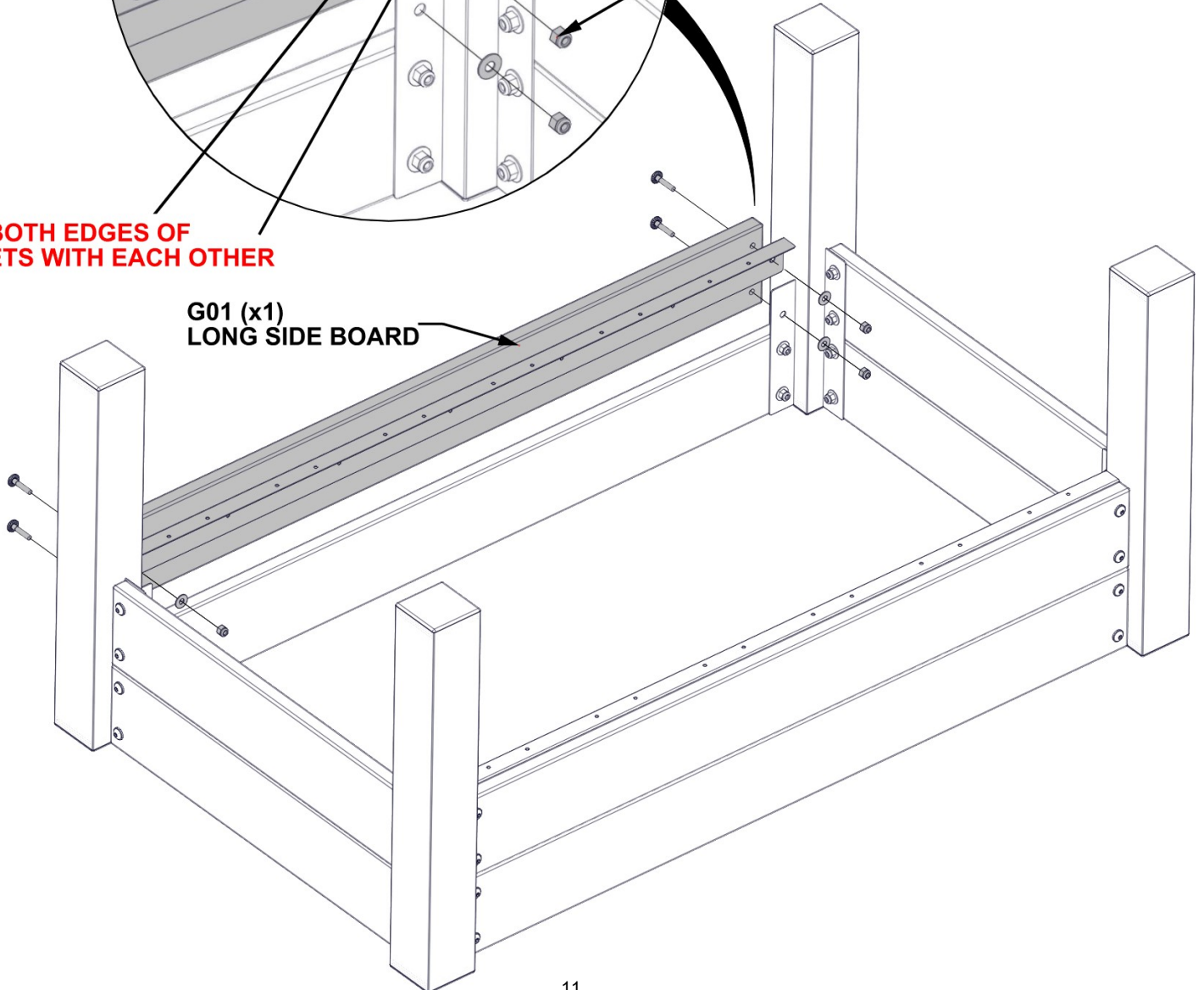

# STEP 6 - PLANTER ASSEMBLY

QTY	PART NUMBER	DESCRIPTION
5	H100202	SCREW PWH 8x5/8 BLK

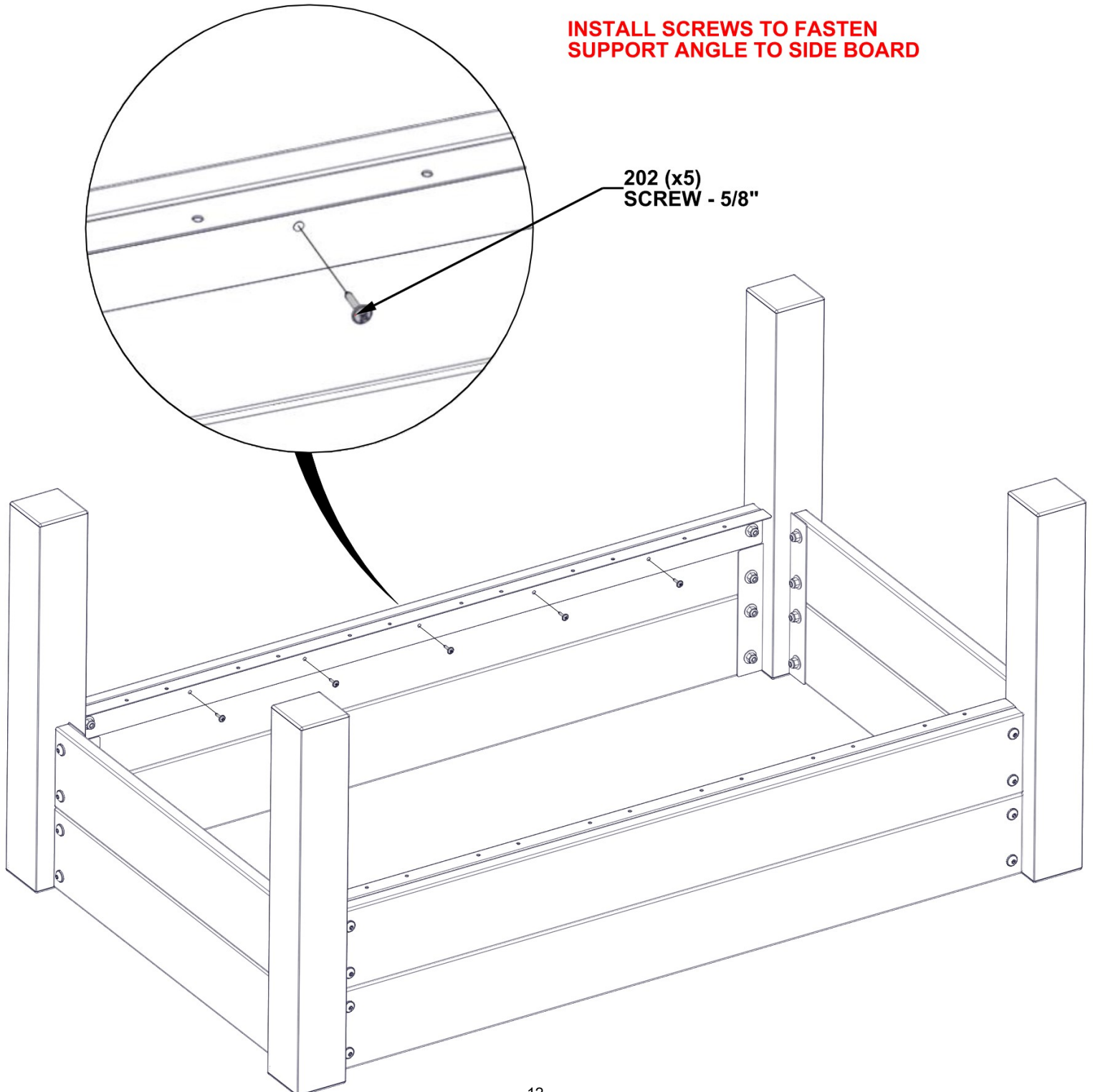

# STEP 7 - PLANTER ASSEMBLY

QTY	PART NUMBER	DESCRIPTION
5	H100202	SCREW PWH 8x5/8 BLK

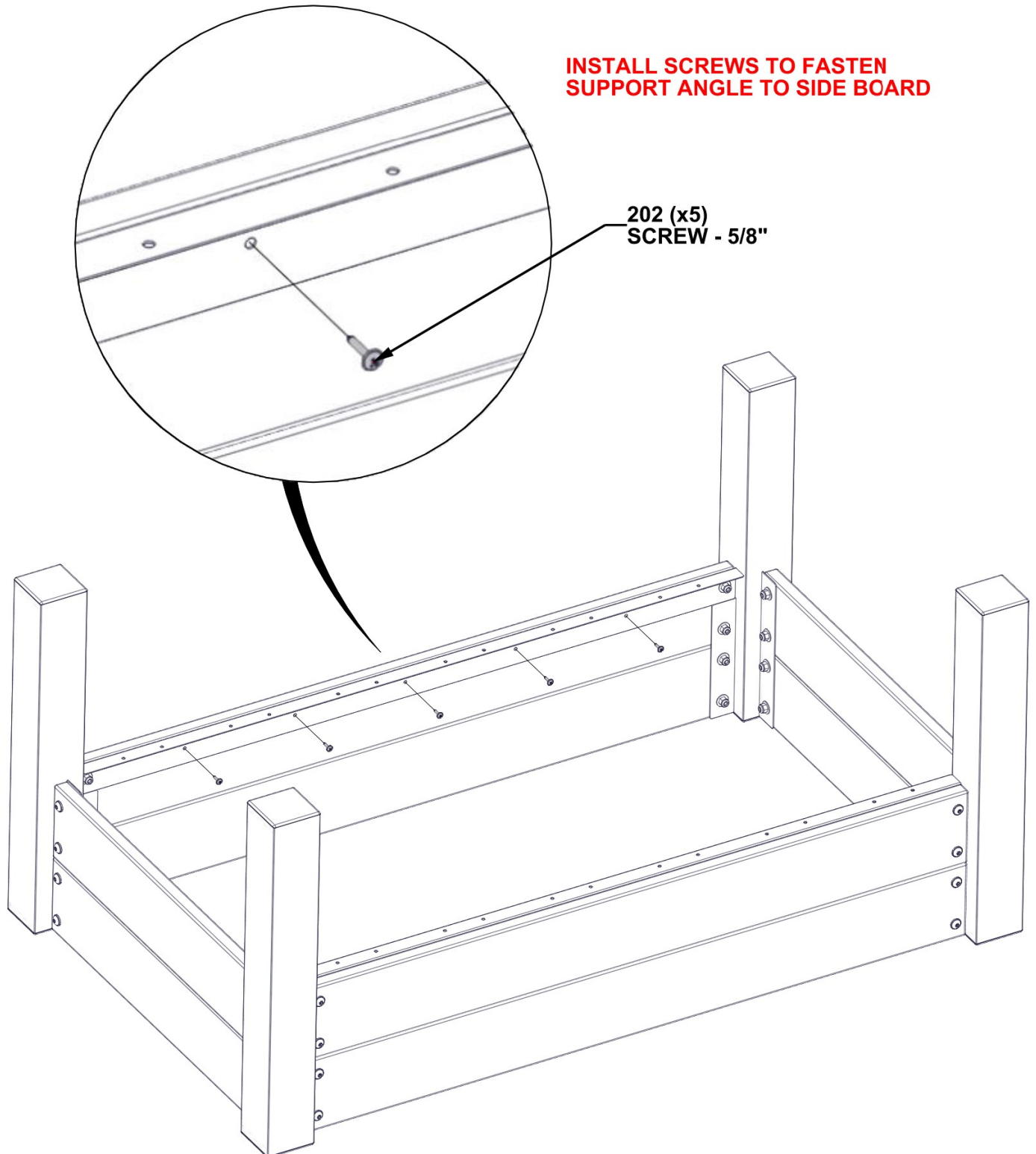

# STEP 8 - PLANTER ASSEMBLY



**G03 | SLAT-W4L16328**  
(x6) | 7/8"x4 3/4"x24 1/2" (22x120x623)

QTY	PART NUMBER	DESCRIPTION
24	H100202	SCREW PWH 8x5/8 BLK

**ALIGN PILOT HOLES IN SLATS WITH HOLES IN SUPPORT BRACKET. SCREW IN PLACE.**

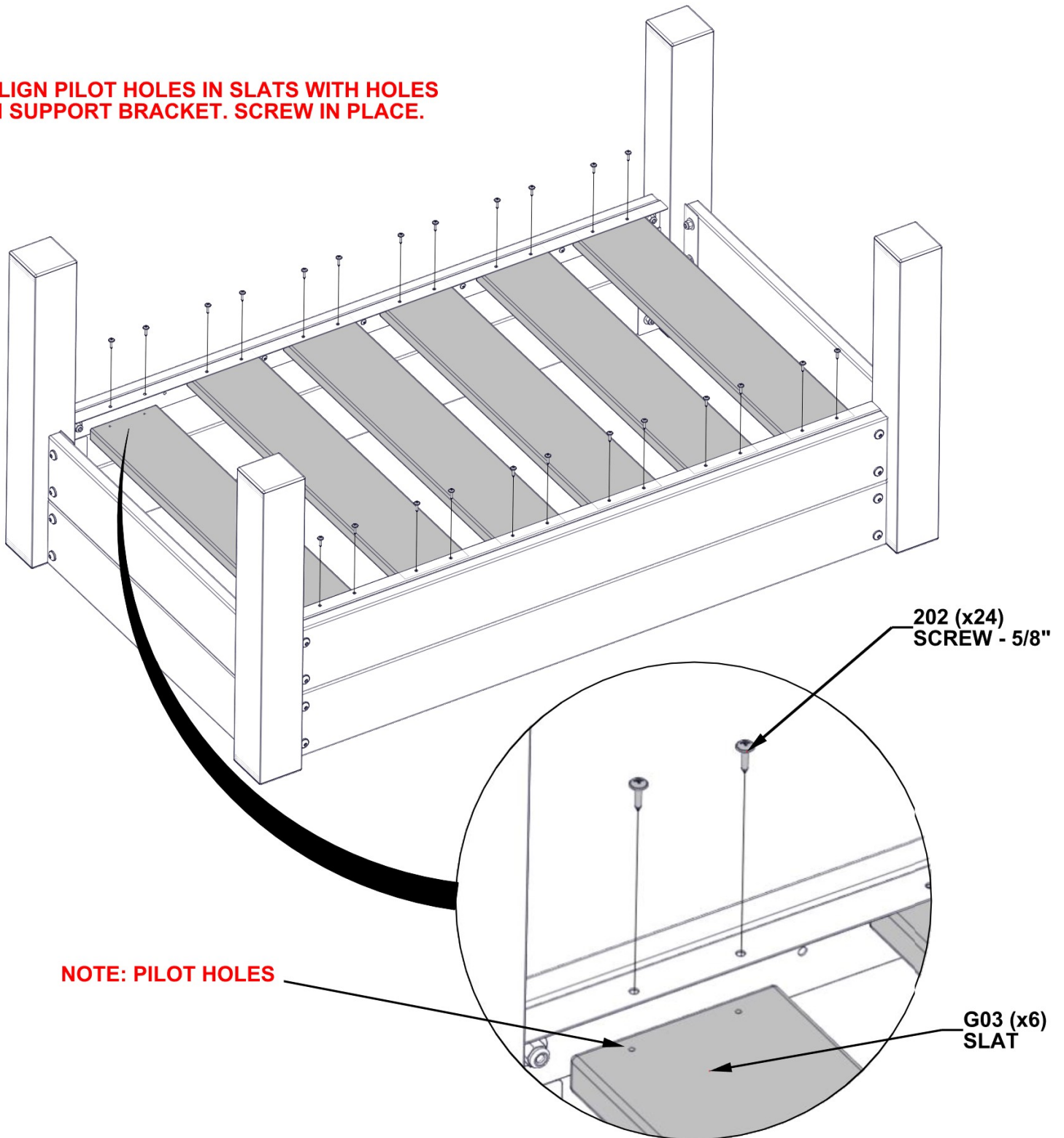

# STEP 9 - PLANTER ASSEMBLY

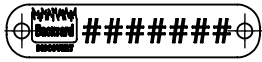

A4M01229 | PRODUCT NUMBER TAG  
(x1)

QTY	PART NUMBER	DESCRIPTION
2	H100127	SCREW 4x1/2 BLK

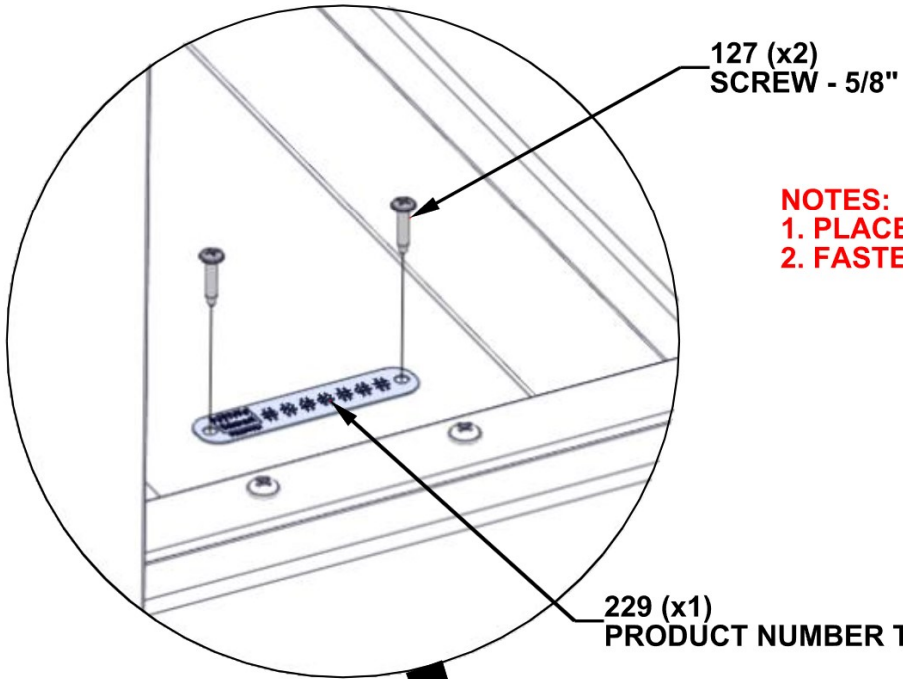

**NOTES:**  
1. PLACE PRODUCT NUMBER TAG ON SLAT.  
2. FASTEN TAG AS SHOWN.

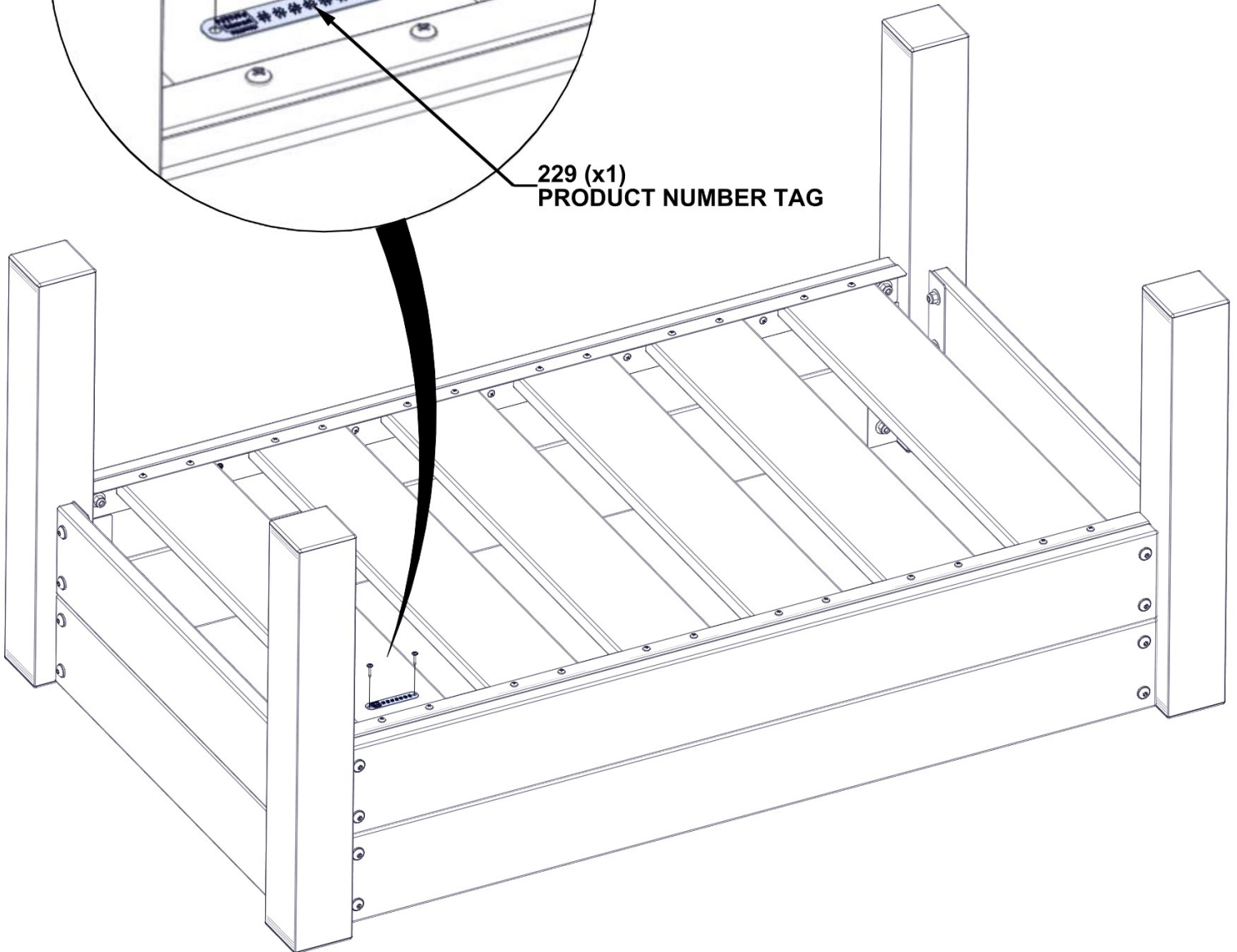

# STEP 10 - PLANTER ASSEMBLY

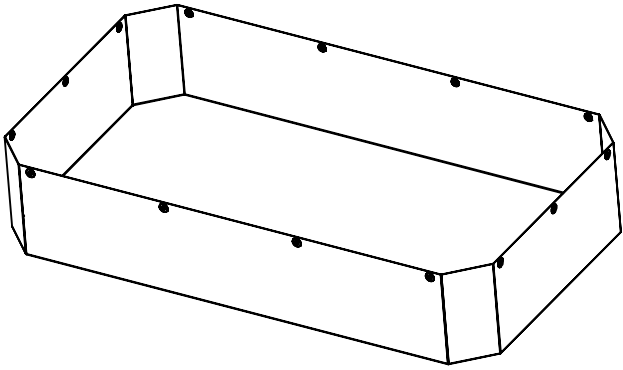

**A6P00510** | PLANTER LINER  
(x1)

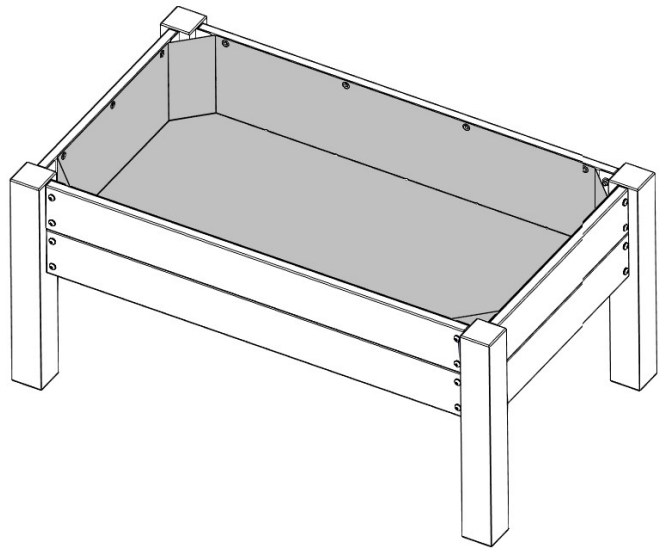

**PLACE PLANTER LINER INTO PLANTER.**

**510 (x1)**  
PLANTER LINER

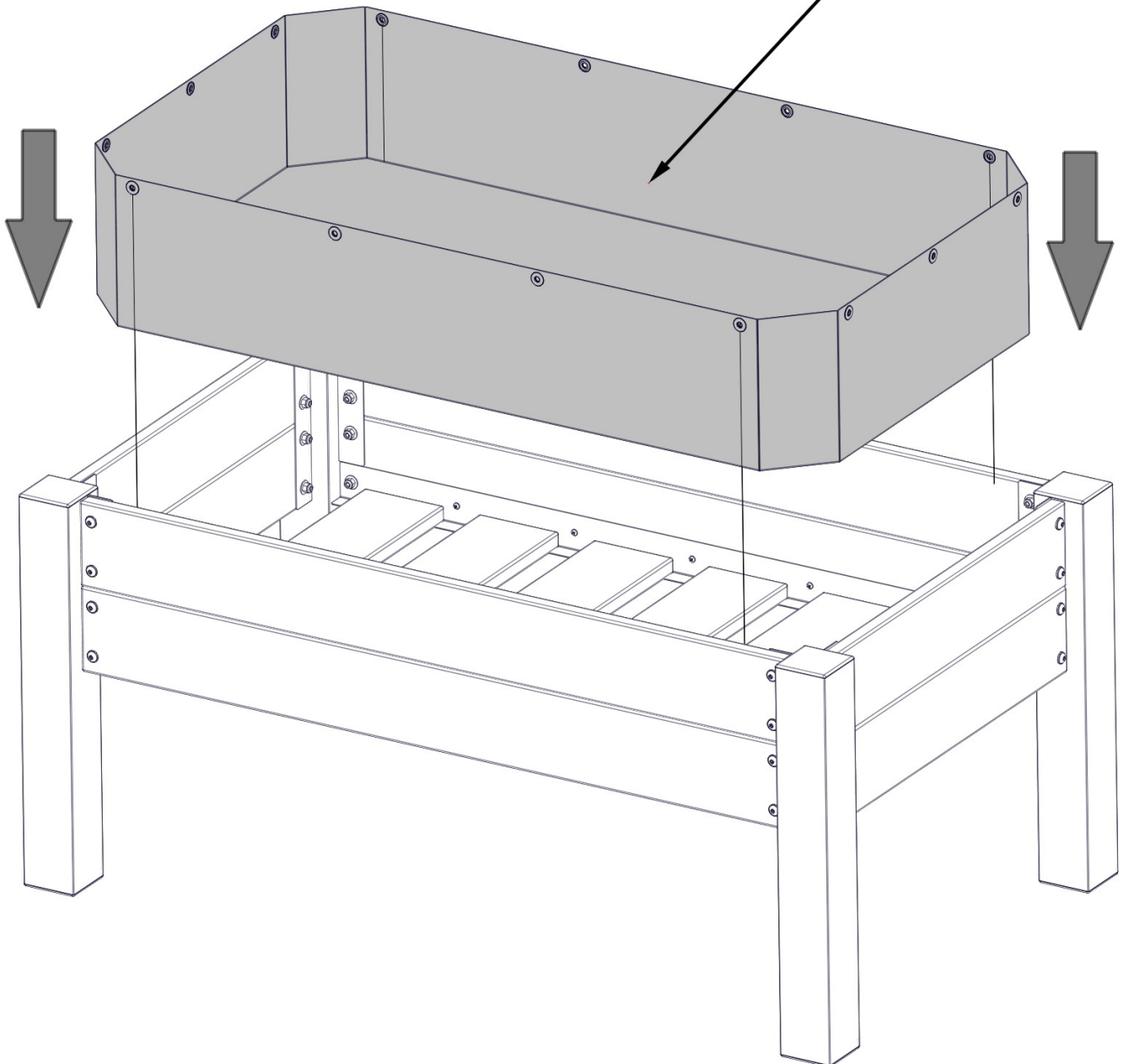



# STEP 11 - PLANTER ASSEMBLY

QTY	PART NUMBER	DESCRIPTION
14	H100202	SCREW PWH 8x5/8 BLK

## NOTES:

1. INSTALL PLANTER LINER BY PULLING CORNERS UP AGAINST EACH POST.
2. TOP EDGE OF LINER SHOULD BE FLUSH WITH TOP OF BOARD.
3. SCREW LINER IN PLACE AS SHOWN.

FLUSH

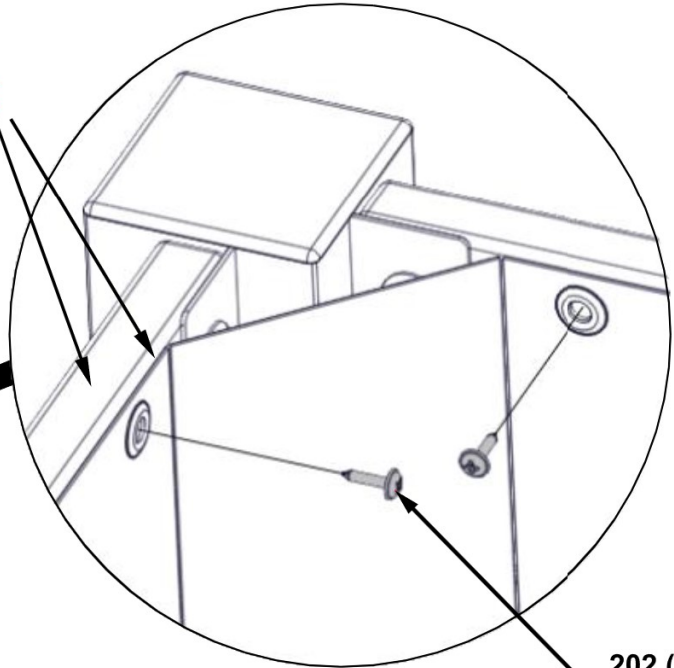

202 (x14)  
SCREW - 5/8"

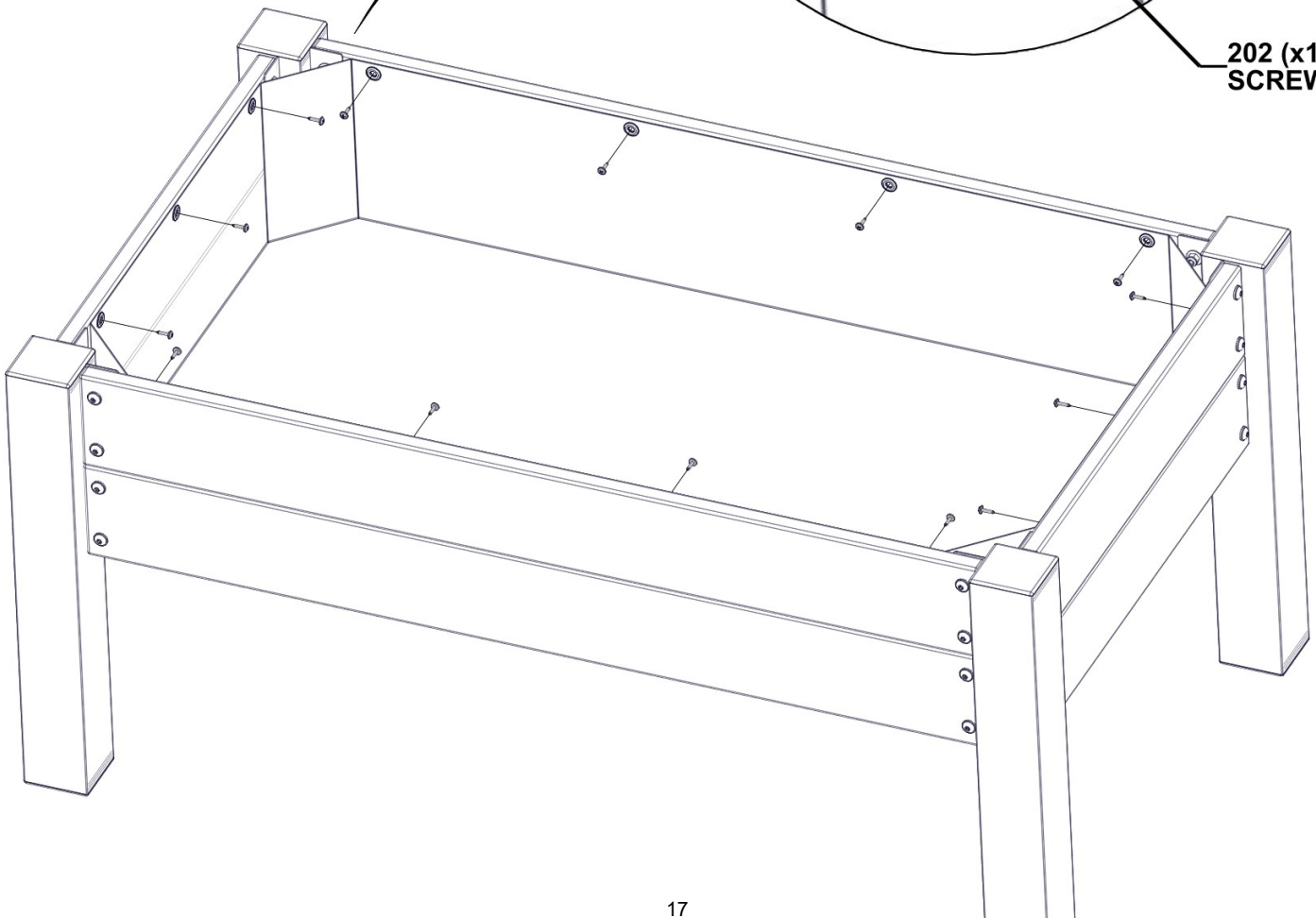

# STEP 12 - PLANTER ASSEMBLY



QTY	PART NUMBER	DESCRIPTION
2	H100202	SCREW PWH 8x5/8 BLK

A100241  
(x1) | BYD ID TAG

**CENTER ID TAG AS SHOWN**

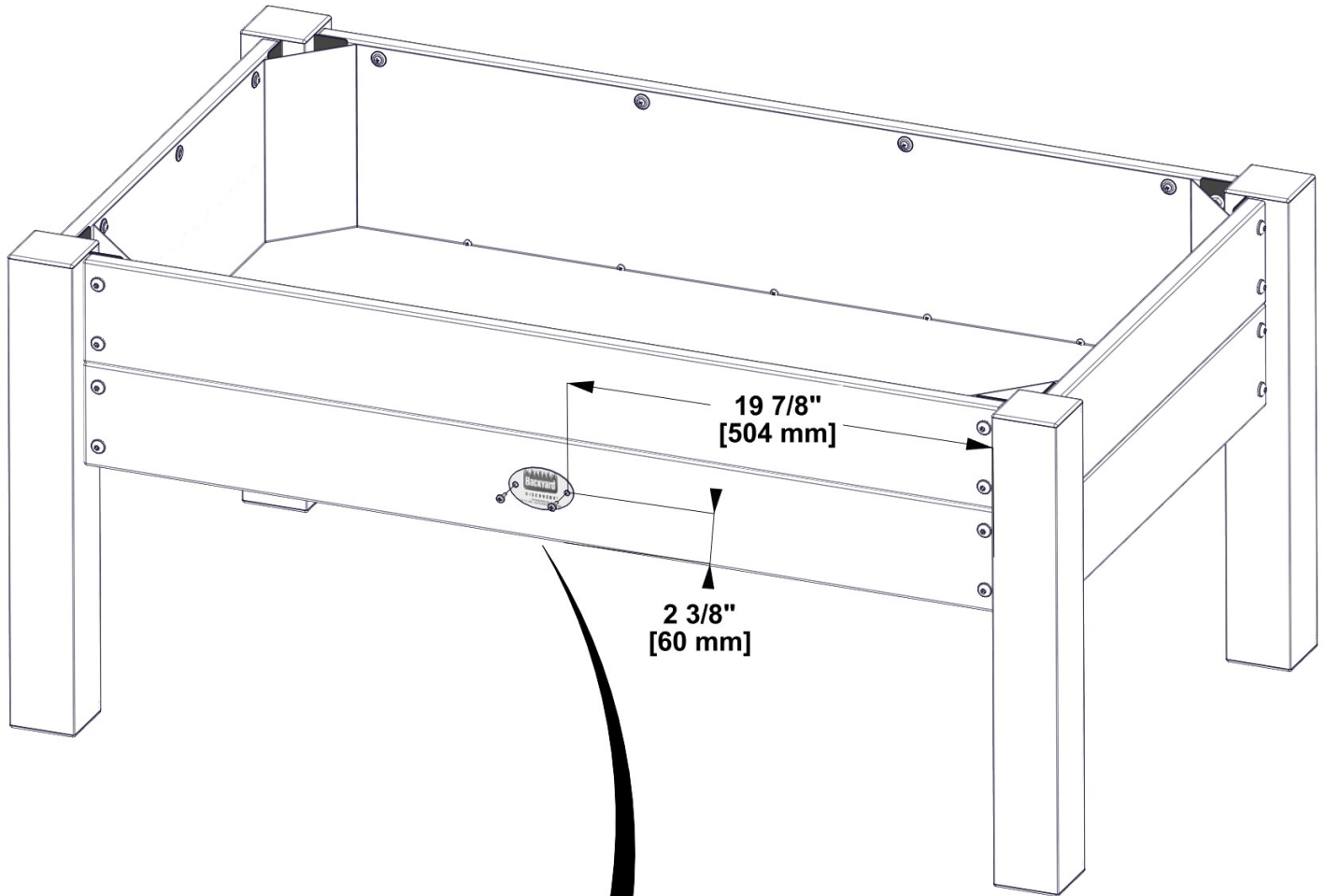

202 (x2)  
SCREW - 5/8"

241 (x1)  
BYD ID TAG

